

SECTION C-C
SCALE 1 : 1

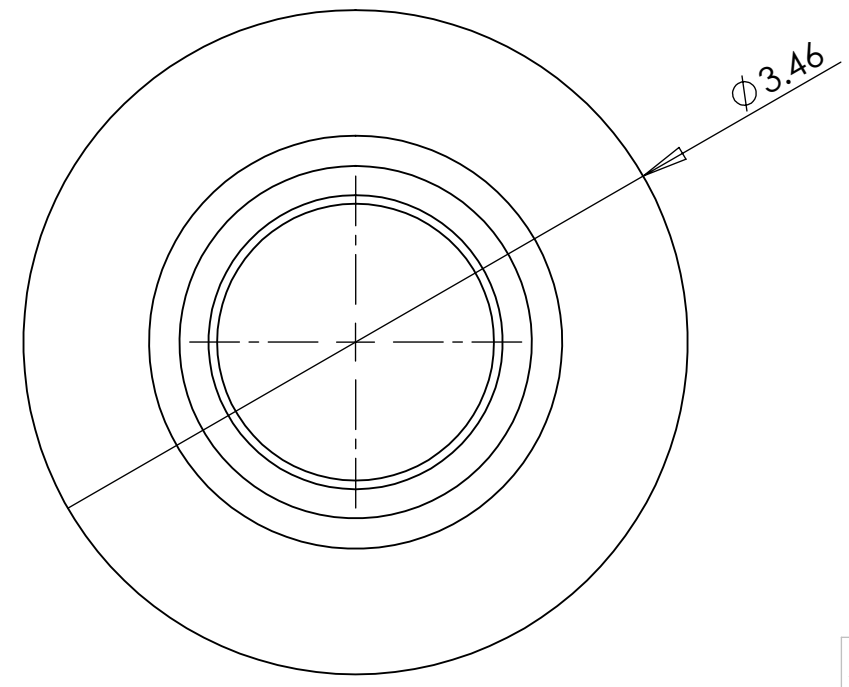

PROPRIETARY AND CONFIDENTIAL
 THE INFORMATION CONTAINED IN THIS DRAWING IS THE SOLE PROPERTY OF Bolt and Caps. ANY REPRODUCTION IN PART OR AS A WHOLE WITHOUT THE WRITTEN PERMISSION OF Bolt and Caps IS PROHIBITED.

| | | | |
|--------------------------------------|-----------|------|----------|
| UNLESS OTHERWISE SPECIFIED: | DRAWN | NAME | DATE |
| DIMENSIONS ARE IN INCHES | CHECKED | TQ | 04/16/09 |
| TOLERANCES: | ENG APPR. | | |
| FRACTIONAL ± | MFG APPR. | | |
| ANGULAR: MACH ± BEND ± | Q.A. | | |
| TWO PLACE DECIMAL ± | COMMENTS: | | |
| THREE PLACE DECIMAL ± | | | |
| INTERPRET GEOMETRIC TOLERANCING PER: | | | |
| MATERIAL ---- | | | |
| FINISH ----- | | | |
| DO NOT SCALE DRAWING | | | |

TITLE:
grout sleeve

| | | |
|------------------|--------------|-----------------|
| SIZE B | DWG. NO. | REV A |
| SCALE: 1:2 | SHEET 1 OF 1 | |