

8 7 6 5 4 3 2 1

| REVISIONS | | | | |
|-----------|------|-----------------------------|---------|----------|
| ZONE | REV. | DESCRIPTION | DATE | APPROVED |
| | B | tapered shaft 2.06 Degrees. | 8/04/15 | |

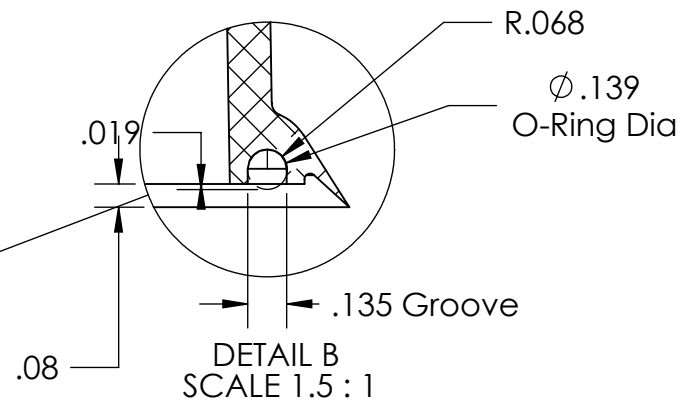
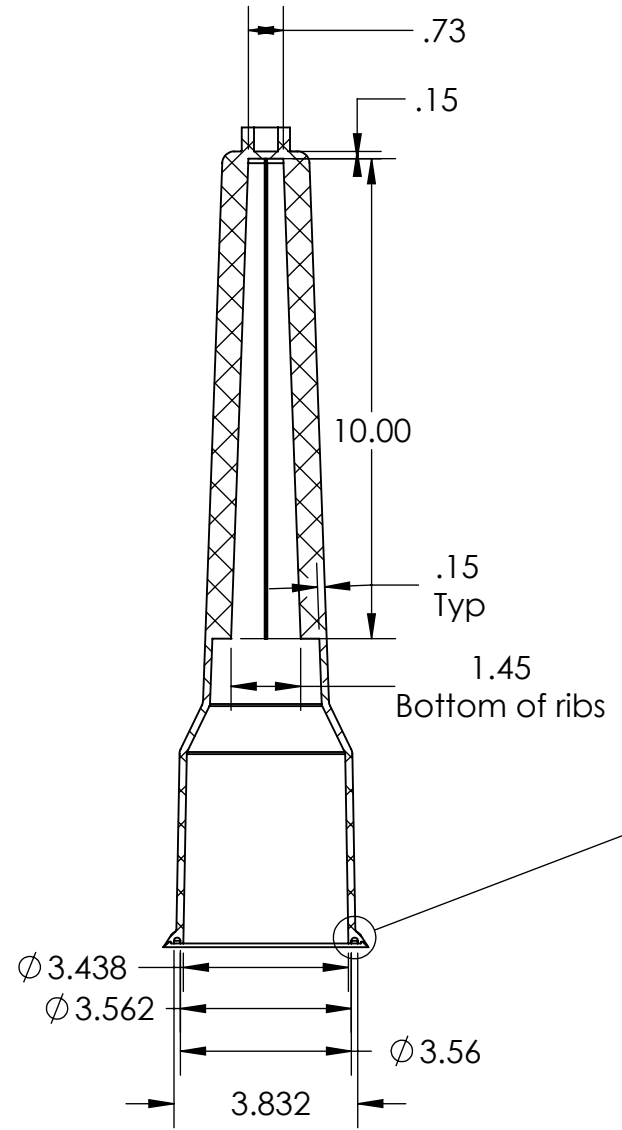
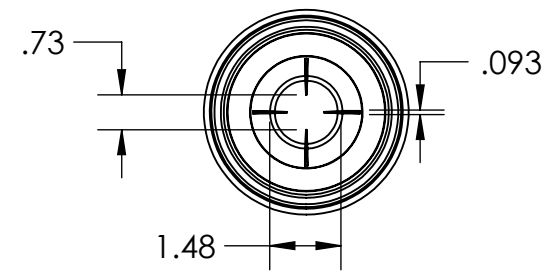
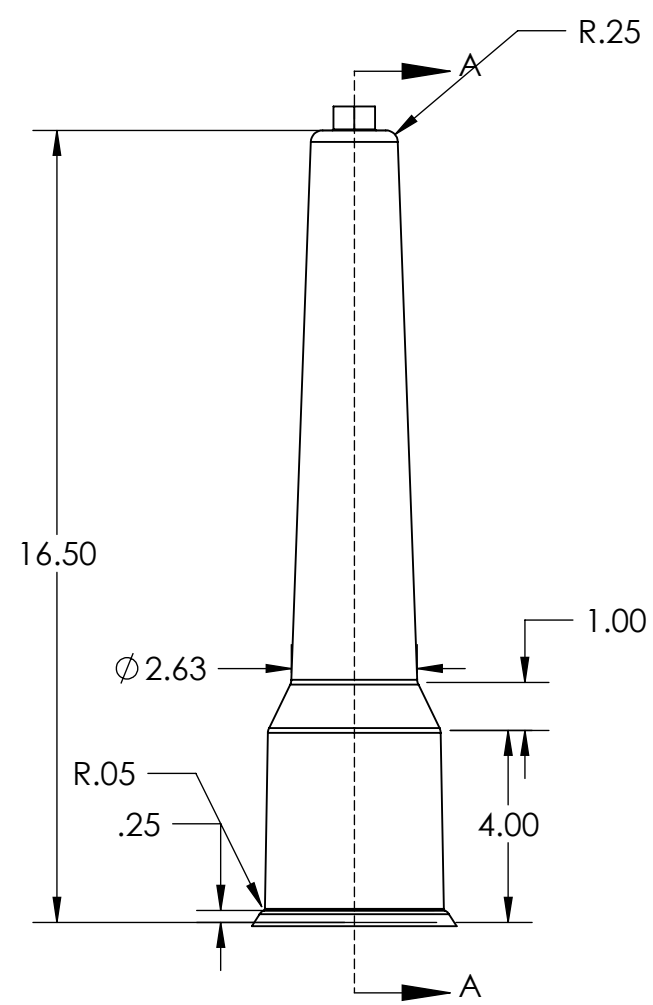
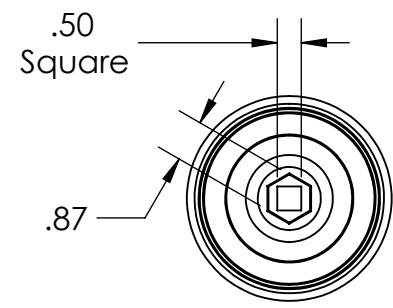

SECTION A-A
SCALE 1 : 4

| | | | |
|--------------------------------------|-----------|------|--------|
| UNLESS OTHERWISE SPECIFIED: | DRAWN | NAME | DATE |
| DIMENSIONS ARE IN INCHES | CHECKED | TQ | 8/6/11 |
| TOLERANCES: | ENG APPR. | | |
| FRACTIONAL ± | MFG APPR. | | |
| ANGULAR: MACH ± | Q.A. | | |
| BEND ± | COMMENTS: | | |
| TWO PLACE DECIMAL ± | | | |
| THREE PLACE DECIMAL ± | | | |
| INTERPRET GEOMETRIC TOLERANCING PER: | | | |
| MATERIAL ---- | | | |
| FINISH ----- | | | |
| DO NOT SCALE DRAWING | | | |

PROPRIETARY AND CONFIDENTIAL
THE INFORMATION CONTAINED IN THIS DRAWING IS THE SOLE PROPERTY OF Bolt and Caps. ANY REPRODUCTION IN PART OR AS A WHOLE WITHOUT THE WRITTEN PERMISSION OF Bolt and Caps IS PROHIBITED.

| | | |
|------------------|--------------|-----------------|
| TITLE: _____ | | |
| SIZE B | DWG. NO. | REV B |
| SCALE: 1:5 | SHEET 1 OF 1 | |

8 7 6 5 4 3 2 1